

# Freestanding French Door Refrigerator Freezer, 90cm, 569L, Ice & Water

Series 7 | Contemporary

Black Stainless Steel | French hinge



Make a statement in black. With large capacity and flexible storage, water dispenser and ice maker, this model has style and substance.

- ActiveSmart™ technology helps keep food fresher for longer by constantly maintaining the ideal temperature.
- Door water dispenser and internal ice maker

- Spacious bottom freezer with full extension drawer gives easy access to frozen goods.

## DIMENSIONS

Height	1790 mm
Width	900 mm
Depth	695 mm

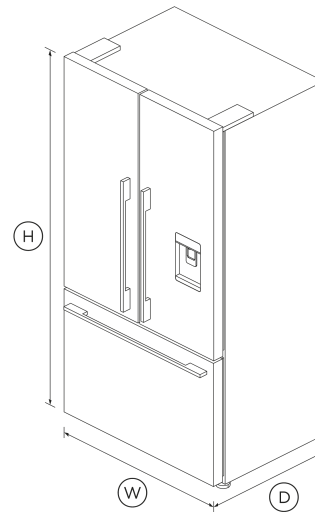

## FEATURES & BENEFITS

### Clever energy

Your refrigerator adapts to daily use by cooling and defrosting only when needed. This means it uses the energy it needs without compromising on food care.

### Easy to clean

No more dirty marks with our EZKleen feature for stainless steel fridges. Anti-fingerprint coating lets you simply wipe clean any finger marks. Spill-safe secure glass shelves easily capture any drips or leaks.

### Design quality

Our fridges are designed and built using robust, quality materials, with stainless steel exteriors and solid glass for the interior shelving.

### Humidity control

Your fruit and veges need different environments. The humidity control slides in each storage bin create a microclimate that helps keep food fresher for longer.

### Ice maker

The internal ice maker delivers fresh ice to a dedicated freezer bin. Simply turn it off to free up freezer space or during busy times boost ice production by up to 30%.

### Ultra slim water dispenser

The slimline water dispenser is easy to use. The angled water delivery means that almost any size or shape of vessel can be filled, while taking up no storage space in your fridge door.

## SPECIFICATIONS

### Accessories (sold separately)

Water filter replacement **847200 - FWC3**

### Capacity

Total net volume **569L**  
 Volume freezer **152 L**  
 Volume refrigerator **417 L**

**Consumption**

Energy rating	E
Energy usage	297kWh/year
In-use energy carbon emissions estimate	91.7kgCO2e/year

**Features**

Adjustable door shelves	6
Adjustable glass shelves	3
Covered door shelves	2
Deli storage bins	2
Door alarm	•
Fruit and vegetable bins	2
LED lighting	•
SmartTouch control panel	•
Stackable bottle holders	4
Ultra slim water dispenser	•
Water Filter	Part number 847200

**Freezer Features**

Automatic ice maker	•
Bottle chill	•
Door alarm	•
Fast freeze	•
Ice bin and scoop	•
Ice Boost	•
LED Lighting	•

**Performance**

ActiveSmart™ Foodcare	•
Adaptive defrost	•
Frost free freezer	•
Humidity control system	•
Inverter controlled compressor	•
Noise emissions	42 dBA
Noise emissions class	D
Sabbath mode	•

**Power requirements**

Supply voltage	220 - 240 V
----------------	-------------

**Product dimensions**

Depth	695 mm
Height	1790 mm
Width	900 mm

**Warranty**

Parts and labour	5 years
------------------	---------

SKU	26684
-----	-------

The product dimensions and specifications in this page apply to the specific product and model. Under our policy of continuous improvement, these dimensions and specifications may change at any time. You should therefore check with Fisher & Paykel's Customer Care Centre to ensure this page correctly describes the model currently available. © Fisher & Paykel Appliances Ltd 2020

**Other product downloads available at fisherpaykel.com**

- [↓ Declaration of Conformity Refrigeration with WiFi Capability](#)
- [↓ Energy Label Freestanding French Door Refrigerator Freezer](#)
- [↓ Service & Warranty](#)
- [↓ Water Filter Replacement Instructions & Installation Guide EN](#)
- [↓ Installation Guide](#)
- [↓ Product Information Sheet](#)
- [↓ Product Information Sheet Freestanding Fridge Freezer](#)
- [↓ User Guide](#)

**Where applicable:**

All appliances use energy, and energy usage typically generates carbon emissions. **Fisher & Paykel Appliances' In-use Energy Carbon Emissions Estimate** indicates carbon emissions from a product's in-use energy. This is calculated either annually or per cycle, using the product's market-specific energy label energy consumption data multiplied by the carbon emissions factor for energy in your country or region.

Our In-use Energy Carbon Emissions Estimate is designed to assist customers in making informed purchasing decisions when comparing different Fisher & Paykel products. For example, a heat pump dryer typically has a lower In-use Energy Carbon Emissions Estimate than a vented dryer.



**A PEACE OF MIND SALE**  
**24 Hours 7 Days a Week Customer Support**  
 T 1800 625174 W www.fisherpaykel.com